



Design and Comparison of Symmetric Compensation Method for DWDM System and WDM by Using Optisystem

Ali F. Kaeib^{*}, Lamia K. Amhimmed², Sajeda J. Aldridi³

***Corresponding author:**
ali.kaeib@sabu.edu.ly Department of Electric and Electronic Engineering, Faculty of Engineering, Sabratha University, Libya.

² Department of Electric and Electronic Engineering, Faculty of Engineering, Sabratha University, Libya.

³ Department of Electric and Electronic Engineering, Faculty of Engineering, Sabratha University, Libya.

Received:
09 October 2023

Accepted:
13 March 2024

Publish online:
31 December 2024

Abstract

Optical fibers are used in Wavelength Division Multiplexing (WDM) networks for transmitting data in the form of light pulses between the transmitter and the receiver. Multiple signals could potentially be transmitted at once using WDM systems. The light signals, however, lose strength as they move through the fiber over a significant distance. Therefore, to restore the original signal after a specific amount of time has passed since light propagation, all light signals must be amplified simultaneously. With increasing distance, the signal is exposed to less dispersion because of the employment of two different types of optical fibers, referred to as Dispersion fibers. The SMF type was enhanced with compensation fiber (DCF), and the outcomes of the two designs were contrasted to decide which is the greatest and most dependable. Using the Optisystem program, this study simulates a four-channel optical communication system and tests it at various distances to determine the ideal distance at which the most data may be communicated. Analysis of the data led to the calculation of crucial parameters such as the Q-factor, BER, and eye diagram, The results varied depending on the length of the cable and the rate of transmitted data.

Keywords: WDM, DWDM, DCF, Optisystem, BER, Q-Factor.

INTRODUCTION

Because of several advantages such as low loss, cheap cost, easy amplification, low interference, and lightweight, optical fiber communication has been increasingly popular for long-distance data transport in recent years. A simple optical telecommunication system consists of a transmitter, a medium, and a receiver.

The optical network that applies wavelength division multiplexing (WDM) is currently widely used in existing telecommunication infrastructures and is expected to play a significant role in next-generation networks and the future Internet, Normal WDM, CWDM and DWDM are three types of WDM technology.

This paper then uses two types of these types: WDM and DWDM, where WDM can be created using a cable of the type SMF, but the transmission distance will be short. On the other hand, we can use DWDM, which can be created using DCF cable, which can transmit over long distances, almost twice the distance obtained on them using an SMF cable, so DWDM technology is better. (Vijayakumar, 2019)



The Author(s) 2024. This article is distributed under the terms of the Creative Commons Attribution-NonCommercial 4.0 International License [<http://creativecommons.org/licenses/by-nc/4.0/>], which permits unrestricted use, distribution, and reproduction in any medium, for non-commercial purposes only, provided you give appropriate credit to the original author(s) and the source, provide a link to the Creative Commons license, and indicate if changes were made.

WAVELENGTH DIVISION MULTIPLEXING (WDM)

A wavelength division multiplexer (WDM), as demonstrated in figure 1 which is used in fiber-optic communications, is a different type of multiplexer. It's a technique for analog multiplexing. It's made for fiber cable with a high data rate capability. The communication channel's bandwidth should be bigger than the combined bandwidth of the different channels in this technique. Here, signals are transformed into light signals, which are then delivered across the same fiber connection with multiple wavelengths. (Vijayakumar, 2019)

WDM divides the optical fiber bandwidth into several no-overlapping optical wavelengths, which are referred to as WDM channels in the WDM transmission system. WDM combines and transmits all incoming signals with varied wavelengths over a single channel. A de-multiplexer reverses the process, separating the wavelengths. This multiplexing method increases the available transmission capacity significantly. (A.F. Kaeib, 2022)

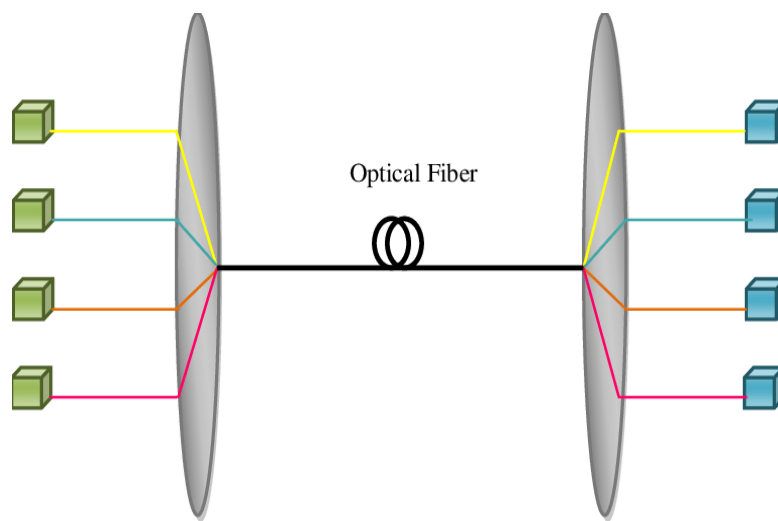

Figure: (1). Wavelength-division multiplexing WDM (A.F. Kaeib, 2022)

TYPES OF WDM

Today's WDM technology mostly falls into two categories:

A. Coarse Wavelength Division Multiplexing (CWDM):

WDM systems with fewer than eight active wavelengths per fiber are referred to as CWDM. CWDM utilizes wide-range frequencies with widely separated wavelengths since it is employed for short-range communications. Standardized channel spacing allows for wavelength variation due to the operation-related heating and cooling of lasers. When spectral efficiency is not a crucial requirement, CWDM is a small and affordable solution. (Vijay akumar, 2019)

B. Dense Wavelength Division Multiplexing (DWDM):

With its ultimate scalability and reach for fiber networks—establishing transport connections as short as tens of kilometers—DWDM is a form of WDM technique, an optical multiplexing technology used to improve bandwidth over existing fiber networks. WDM that uses closely spaced channels is known as dense WDM (A.F. Kaeib, 2022)

CHARACTERISTIC OF AN OPTICAL FIBER

Signal attenuation is one of optical fiber's key characteristics. Another crucial characteristic of optical fiber is the distortion mechanism, which is also known as fiber loss or signal loss.

A. Attenuation

As the light pulse moves from one end of the cable to the other, attenuation refers to a loss of light energy. It is also known as fiber loss or signal loss. It also determines how many repeaters thirty-six in total are needed between the transmitter and receiver. The cable's length is directly inversely correlated with attenuation. The ratio of optical output power to input power in a fiber of length L is known as attenuation (Bass, 2002)

$$\alpha = 10 * \log_{10} \frac{P_i}{P_o} [/ km] \dots \dots \dots (1)$$

where:

α is the attenuation constant

P_i : Input Power, P_o : Output Power,

The cable's varied losses are caused by

- Absorption
- Bending Loss
- Scattering

B. The dispersion

In an optical fiber, it is described as pulse spreading. A laser pulse broadens as it travels through a fiber due to factors like numerical aperture, core diameter, refractive index profile, wavelength, and laser line width. Along the fiber's length, dispersion grows. Inter-symbol Interference (ISI) refers to the overall impact of dispersion on a fiber optic system's performance. When dispersion-induced pulse spreading causes a system's output pulses to overlap, inter-symbol interference results. (Bass, 2002)

DISPERSION COMPENSATION TECHNIQUES

These are the dispersion compensating methods that are most frequently used:

- Electronic dispersion compensation (EDC).
- Fiber Bragg Grating (FBG).
- Digital Filters.
- Dispersion Compensating Fibers (DCF).

DISPERSION COMPENSATING FIBERS (DCF)

Dispersion compensating fibers (DCF) were first proposed as a method in 1980. Wide bandwidth and temperature do not readily alter the DCF component parts. One of the most used strategies for dispersion is DCF. A DCF is a fiber loop with a transmitting fiber's dispersion plus a negative amount. The terms pre-compensation, post-compensation, and symmetrical compensation can be used to describe it. It is the initial method of compensation for dispersion compensation. When the DCF is used between the amplifiers together with a combination of both ways called symmetrical compensation, this type of fiber can be used before the optical fiber called pre-compensation, or after the optical fiber called post-compensation. (Bass, 2002)

With single-mode fiber WDM systems that have high effective areas and low bit error rates, the DCF approach is frequently used. This is a very effective and dependable method, however, when the input power is high, it exhibits substantial insertion loss and nonlinear distortion. In addition to DCF, reverse dispersion fiber (RDF) and dispersion-managed cables (DM) are also used. (Vijay akumar, 2019)

DISPERSION COMPENSATION FIBER ON A PATH

DCF, which reduces the positive dispersion of the transmission lines to make the residual dispersion zero, is one of the best ways to compensate for dispersion with tunable negative dispersion. By using the following equation to determine the length of the DCF, one can make the residual dispersion zero:

$$D_{res} = D_{TF} L_{TF} + D_{DCF} L_{DCF} \dots (2)$$

Where L_{TF} is the transmission length, D_{DCF} is the negative dispersion of the DCF, L_{DCF} is the length of the DCF compensator, and D_{TF} stands for the positive dispersion of the transmission. The dispersion slope must also be corrected in order to account for the positive dispersion over a wide wavelength range. This is how the residual dispersion slope is written:

$$S_{res} = S_{TF} L_{TF} + S_{DCF} L_{DCF} \dots (3)$$

Where S_{TF} is the transmission fiber's positive dispersion slope, L_{TF} is the transmission length, S_{DCF} is the DCF's negative dispersion slope, and L_{DCF} is the DCF compensator's length. There are three alternative dispersion compensation approaches for DCF, as previously discussed. Post-compensation methods place the DCF after the Single Mode Fibre, while pre compensation schemes position the DCF on the side facing the EDFA amplifier. A pre-combination of and post-compensation employing DCF on both sides of a single-mode fibre (SMF) is known as symmetrical compensation . (Kaur, 2016).

SYSTEM DESIGN AND SIMULATION

An optical communication system consists of three components: an optical transmitter, an optical receiver, communication channel, the following figure shows these components.

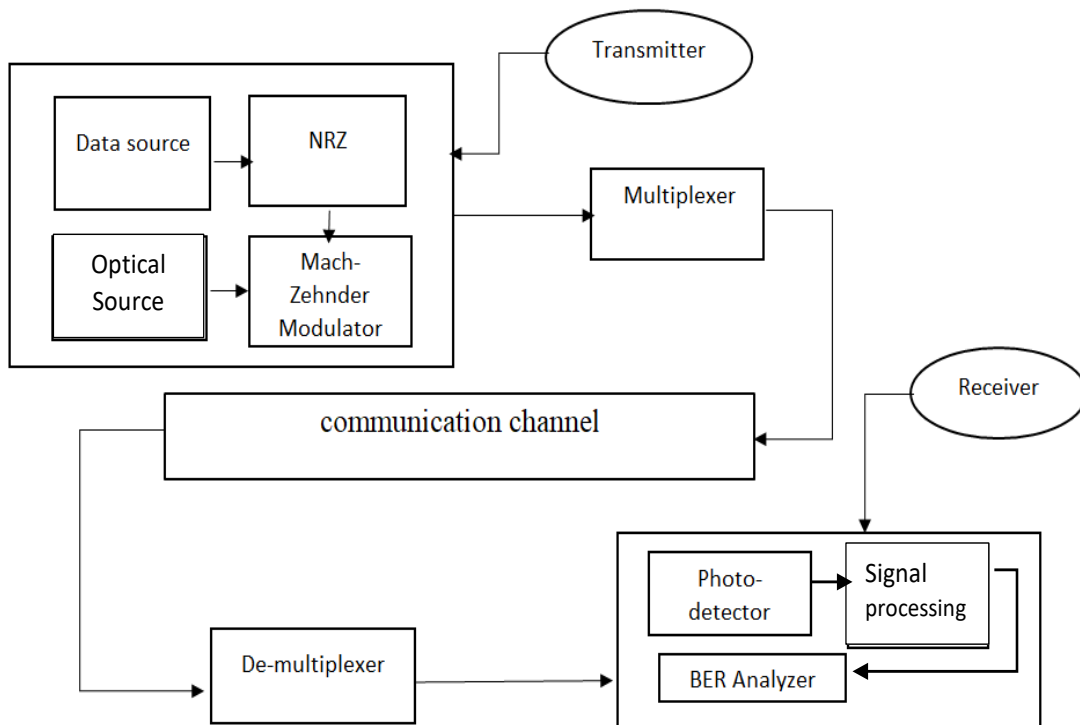

Figure :(2). Basic Optical System Components (Kaur, 2016)

A. The transmitter

The optical transmitter's purpose is to transform an electrical input signal into the matching optical signal and then broadcast that signal across an optical fibre to another device. Table: (1) shows the transmitter's four parts: the data source, the pulse generator, the optical modulator, and the optical source. (Fauza Khair, 2018)

B. The Communication channel

The communication channel's goal is to transmit information without distorting it. An information signal must travel through some kind of channel or medium to be transmitted over space. These "communication channels" can be broadly classified into directed and unguided pathways. Twisted-pair cable, coaxial cable, and fibre optic cable are examples of guided media. The unguided medium, free space, is unbounded and includes guided media. The unguided medium, free space, is unbounded and includes guided media such as microwave, satellite, radio, and infrared. In this project, the carrier is an optical signal that moves the optical signal from transmitter to receiver (Barry Elliott, 2002)

A. The receiver:

The optical receiver is used to convert the optical signal received at the output end of the optical fiber back into the original electrical signal and recover the data transmitted through the light wave system. Its main components as shown in Figure (2) in addition to the BER analyzer are photodetector, and signal processing components as illustrated in Table (2).

Table :(1) Transmitting components







Component name	Symbol	Function
CW laser		Generates optical signal which will be used as the optical carrier
Pseudo –Random Bit Sequence Generator		Generates a Pseudo Random Binary Sequence (PRBS) according to different operation modes
NRZ pulse generator		Converts the binary input comes to it from the bit sequence generator into electrical pulses for modulation purposes
Mach-Zender modulator		Modulates the information signal with the optical carrier signal that comes from the light source .

Table :(2) Receiving components

Component name	Symbol	Function
Optical amplifier		Amplify the optical signal with pre-defined gain in the dB unit.
PIN photodetector		Converts the received optical signal into an electrical signal.
Low-pass filter		remove high-frequency noise and interference from the signal.

The following figures display the circuit design.

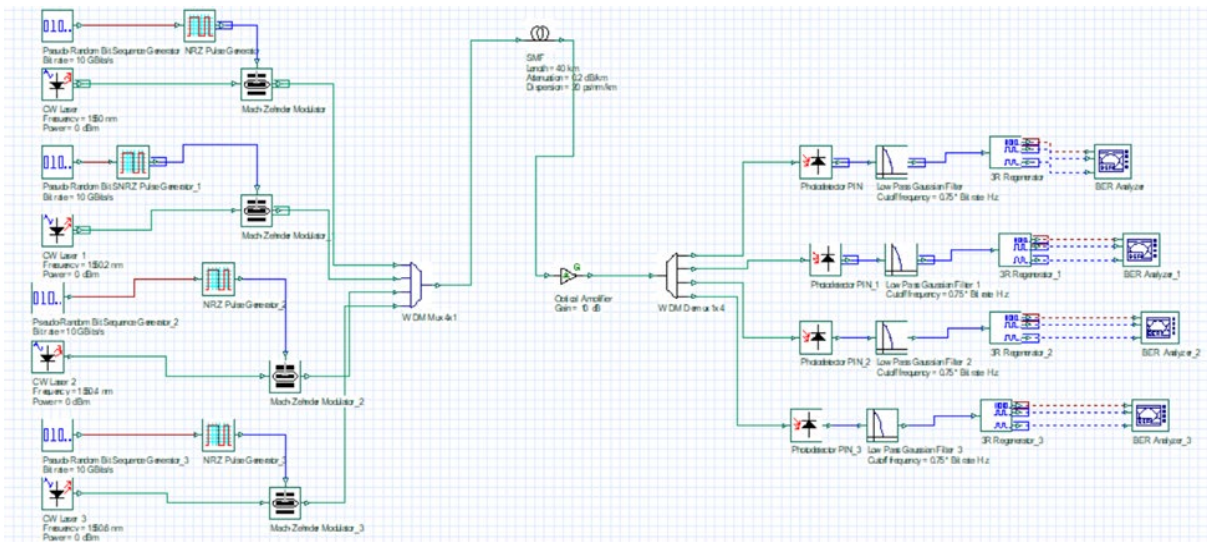

Figure:(3)system simulation scheme of SMF cable

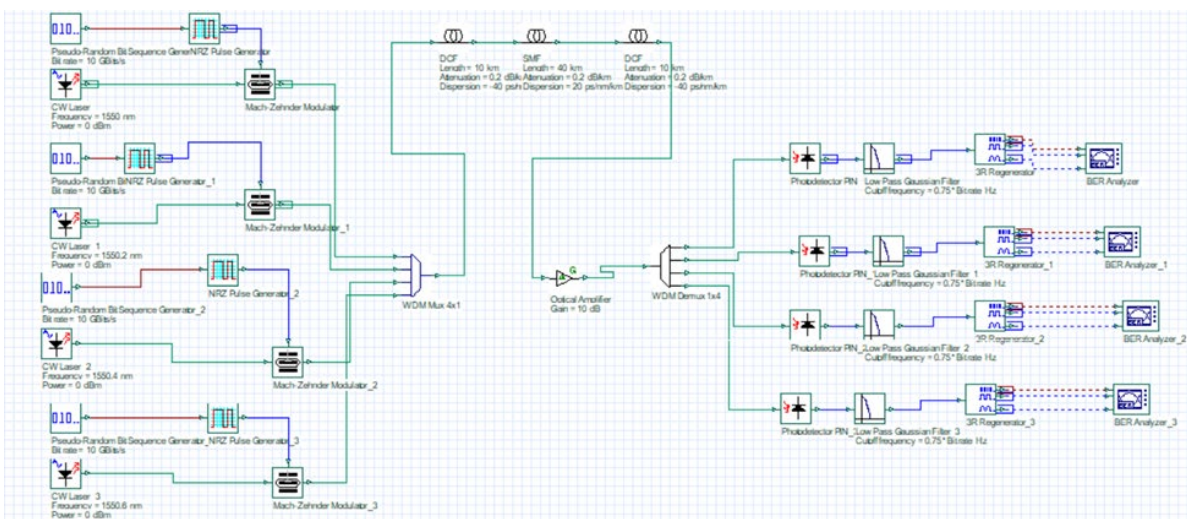

Figure:(4). System simulation scheme of SMF+DCF cables

The user can enter parameters that can be measured from actual equipment using the Optisystem program. To do this, double-click the component to bring up its associated parameters. Different parameters were utilized for the circuit depicted above; some of them vary based on each situation, while others will always be the same. The results table will include the variable parameters, while the constant parameters are an amplifier noise figure of 4 dB and a gain of 10 dB. The PIN photodetector will have a 1 A/W response rate and a 10 nA dark current. The low pass filter will have a depth of 100 dB and a cutoff frequency equal to 0.75 of the bitrate.

RESULTS AND DISCUSSION

Using WDM and DWDM, various channel spacing characteristics were examined. These two scenarios are:

Case one WDM: The communication channel in this scenario is solely made up of Single Mode Fibre SMF and an amplifier EFDA, with no DCF.

Case two DWDM: Single Mode Fibre SMF, EFDA, and 2 -DCF are used as the communication route. In order to compare the two scenarios, examine the changes that take place when the DCF is added to the circuit's communication channel, and estimate the appropriate operating distance for the system, we will use two cases. The laser frequency values between 1550 and 1550.6 were set to four channels with a range of laser input power 2 dBm to 6 dB and varied bit rates 5 Gbit/s, 10 Gbit/s, and 15 Gbit/s and their efficacy was compared in terms of the distance to be covered.

The parameters of the fiber have been set as follows in Table (3):

Table: (3) Fiber parameters

Parameter	DCF	SMF
Length	(25-60) km	(50-120) km
Attenuation	0.2 dB/Km	0.2dB/Km
Dispersion	-40 ps/nm/km	20ps/nm/km

The following tables illustrate the various bit error rates (BER) and Q factors at various distances when the communication channel is consisting of SMF+DCF with EFDA.

Table : (4) SMF results of the Q-factor and BER in 5Gbps and 6dbm

Length (KM)	5Gbps -6dbm							
	1550 nm		1550.2nm		1550.4nm		1550.6nm	
SMF cable	Q Factor	BER	Q-Factor	BER	Q-Factor	BER	Q-Factor	BER
30km	12.351	1.901×10 ⁻³⁵	11.597	1.649×10 ⁻³¹	12.016	1.124×10 ⁻³³	12.636	4.587×10 ⁻³⁷
50km	9.303	5.674×10 ⁻²¹	9.0452	6.141×10 ⁻²⁰	9.305	5.491×10 ⁻²¹	9.694	1.1817×10 ⁻²²
80km	4.327	7.555×10 ⁻⁷	3.928	4.235×10 ⁻⁵	3.997	3.175×10 ⁻⁵	4.3762	5.945×10 ⁻⁶

Table: (5) SMF results of the Q-factor and BER in 10 Gbps and 2dbm

Length (KM)	SMF cable 10Gbps -2dbm							
	1550 nm		1550.2nm		1550.4nm		1550.6nm	
SMF	Q Factor	BER	Q-Factor	BER	Q-Factor	BER	Q-Factor	BER
30km	8.15637	1.406×10 ⁻¹⁶	7.1014	5.201×10 ⁻¹³	8.1147	2.129×10 ⁻¹⁶	7.54029	1.872×10 ⁻¹⁴
50km	5.9203	1.427×10 ⁻⁹	4.98542	2.765×10 ⁻⁷	5.61738	8.941×10 ⁻⁹	5.5018	1.613×10 ⁻⁸
80km	3.835	5.896×10 ⁻⁵	3.67728	0.0001116	3.43676	0.0002733	3.87003	5.251×10 ⁻⁵

Table: (6) SMF+DCF results of the Q-factor and BER in 5Gbps and 2dbm

Length (KM)		5Gbps-2dbm							
		1550 nm		1550.2nm		1550.4nm		1550.6nm	
SMF	DCF	Q-Factor	BER	Q-Factor	BER	Q-Factor	BER	Q-Factor	BER
50	25	15.601	2.683×10^{-55}	14.948	5.858×10^{-51}	15.174	1.852×10^{-52}	16.226	1.07×10^{-59}
80	40	12.200	1.374×10^{-34}	11.624	1.322×10^{-31}	11.434	1.210×10^{-30}	11.479	6.886×10^{-31}
100	50	5.227	8.495×10^{-8}	4.991	2.928×10^{-6}	5.3281	4.920×10^{-8}	4.892	4.77×10^{-7}

The next figures show the eye diagram for the best and the worst result for 5Gp,10Gp bit rate with SMF cable only:

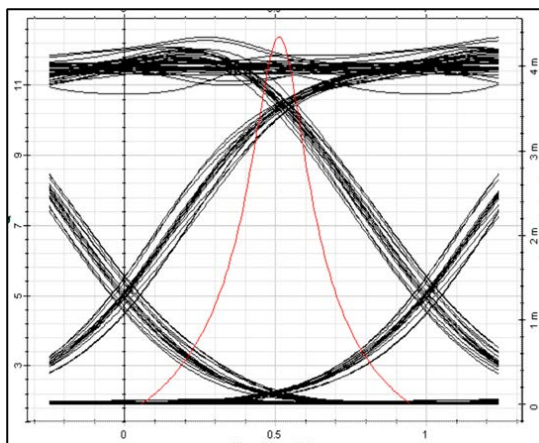

Fig :(5) eye diagram of the best result at 5Gbps with SMF cable

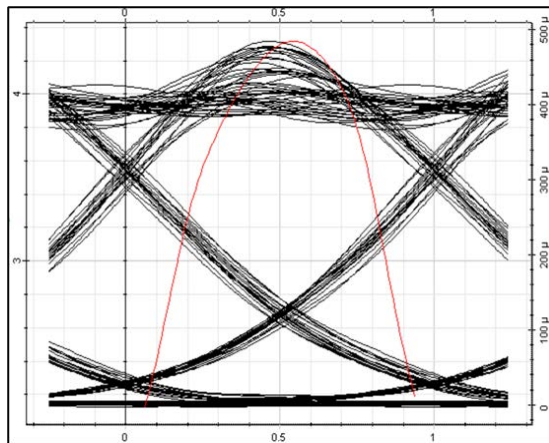

Fig: (6) eye diagram of the worst result at 5Gbps with SMF cable

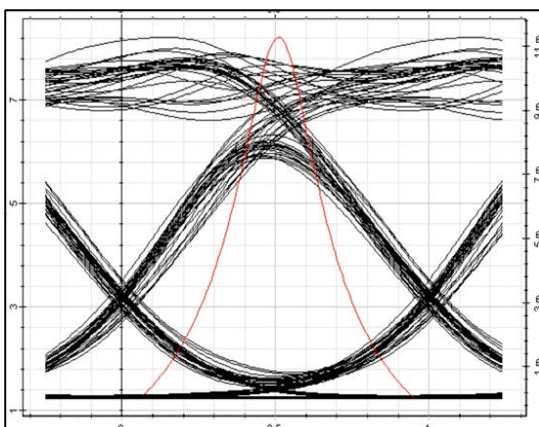

Fig :(7) eye diagram of the best result at 10Gp with SMF cable

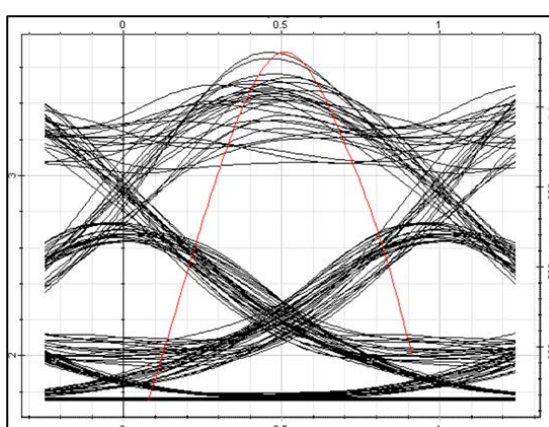

Fig :(8) eye diagram of the worst result at 10Gp with SMF cable

At a bit rate (15Gbps) The results were poor and the data transmission mechanism was inefficient. The system is clearly reliable up to 50 km, The best values of Q-FACTOR were at bit rates of 5

Gbps, and the bit rate 10 Gbps, the values of FACTOR somewhat fell, and at 15 Gbps, the Q-FACTOR was not excellent.

The next figures show the eye diagram for the best and the worst result for 5Gp,10Gp bit rate with SMF and DCF cables :

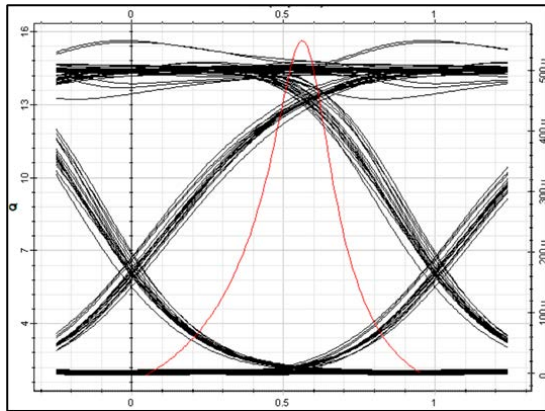

Fig :(8) eye diagram of the best result at 5Gbps with SMF+DCF cable

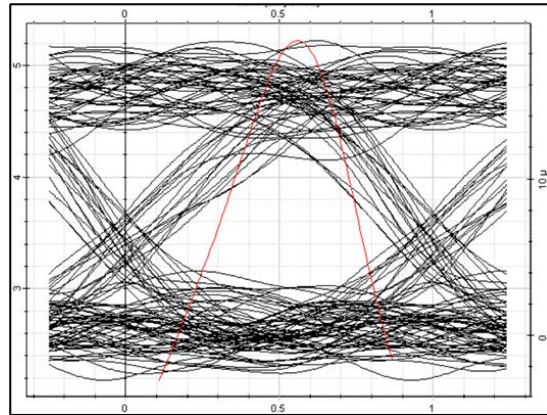

Fig :(9) eye diagram of the worst result at 5Gbps with SMF+DCF cable

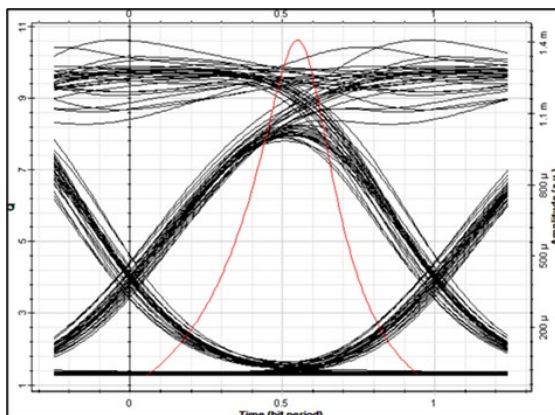

Fig :(10) eye diagram of the best result at 10Gbps with SMF+DCF cable

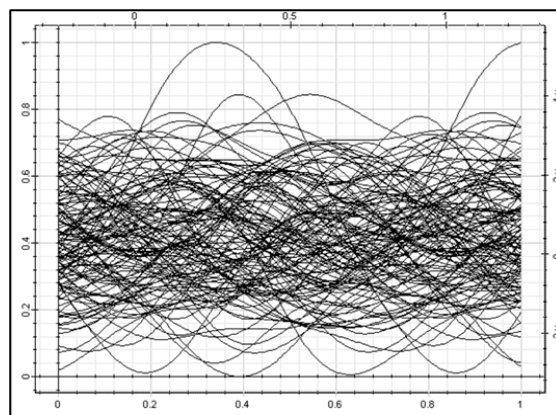

Fig :(11) eye diagram of the worst result at 10Gbps with SMF+DCF cab

At a bit rate (15Gbps), The results were poor and the data transmission mechanism was inefficient. Up to 150 km, the system exhibits a high degree of reliability. At bit rates of 5 Gbps, Q-FACTOR values were at their peak, and as bit rates rose to 10 Gbps, they started to decline considerably. However, at 15 Gbps, Q-FACTOR was not at all acceptable.

CONCLUSION

The longest conceivable distance is examined in this paper. The two configurations were compared using different SMF lengths and DCF+SMF lengths, and it was discovered that the second configuration was more effective at transmitting data due to the presence of DCF, which serves as a dispersion compensation mechanism, as well as the presence of the second one when using a bit rate of 5Gbps. The configuration with only SMF is reliable up to 50 km, while the configuration with

DCF+SMF is reliable up to 150 km. When the wavelength varies within the same band, there is no difference in BER or Q-Factor.

Duality of interest: The authors declare that they have no duality of interest associated with this manuscript.

Author contributions: Contribution is equal between authors.

Funding: No specific funding was received for this work.

REFERENCES

- A.F. Kaeib, O. A. (2022). Designing and Analysis of Underwater Optical Wireless communication system. *Designing and Analysis of Underwater Optical Wireless communication system, Department of Electric and Electronic Engineering, Faculty of Engineer 2022 IEEE 2nd International Maghreb* . Sabratha ,Libya : IEEE.
- Abe, J. I. (2018, August). An In-Depth Analysis of Frequency Division Multiplexing, Time Division Multiplexing, and Time-Compression Multiplexing. Makurdi, Nigeria. Retrieved from https://www.academia.edu/38156174/MULTIPLEXING_FDM_TDM_AND_TCM_pdf
- Barry Elliott, M. G. (2002). *Fiber Optic Cabling*. oxford: Newnes.
- Bass, M. (2002). *FIBER OPTICS HANDBOOK, Fiber, Devices, and Systems for Optical Communications*,. United States of America: McGraw-Hill Professional.
- Fauza Khair, I. W. (2018). Comparative Analysis of Dispersion Compensating Fiber in DWDM System Using . *International Conference on Information Technology* . Bali, Indonesia: IEEE.
- Kahlon, N. K. (2014). "Various dispersion compensation techniques for optical system. *Open journal of communications and software 1.1* .
- Kaur, K. a. (2016). Dispersion compensation techniques: A review. *An International Journal of Engineering Sciences, Special Issue 20*.
- Vijayakumar, D. (2019). Retrieved from raserchgate: https://www.researchgate.net/publication/334056267_Multiplexing